

THE IMPACT OF IT ON MARKET INFORMATION AND TRANSPARENCY: A UNIFIED THEORETICAL FRAMEWORK

Nelson F. Granados
Doctoral Program

Alok Gupta
Professor

Robert J. Kauffman
Director, MIS Research Center,
and Professor and Chair

Information and Decision Sciences
Carlson School of Management, University of Minnesota
Minneapolis, MN 55455
{ngranados, agupta, rkauffman}@csom.umn.edu

Last revised: January 14, 2006

ABSTRACT

With the advent of the Internet, we have seen existing markets transform and new ones emerge. In this paper, we contribute to the understanding of this phenomenon by developing a unified theory about the role that IT plays in affecting market information, transparency and market structure. In particular, we introduce a new theoretical framework which uncovers the process and the forces that, together with IT, facilitate or inhibit the emerging dominance of transparent electronic markets. Transparent electronic markets offer unbiased, complete, and accurate market information. Our effort to develop a unified theoretical framework begins with a thorough assessment of the prior literature. It also uses an inductive approach involving the case study method, in which we contrast and compare the forces that have led the air travel and financial securities markets to become increasingly transparent. Building on the electronic markets and electronic hierarchies research of Malone, Yates and Benjamin [1987], our findings suggest that IT alone does not explain a move to transparent electronic markets. Instead, we argue that enhanced electronic representation of products, and competitive and institutional forces have also played an important role in the process by which most sellers have come to favor transparent markets.

Keywords: Economic theory, electronic commerce, electronic markets and hierarchies, market design theory, market structure, market transparency, theory-building research, unified theoretical framework.

I. INTRODUCTION

The *electronic markets hypothesis* (EMH) posits that IT reduces coordination costs between suppliers and buyers, leading to the dominance of market-based forms of economic activity [Malone et al., 1987]. The primary drivers of this move are advanced ITs such as the Internet, which provide a platform that reduces information search costs. The EMH predicts that, in this technological environment, *biased* electronic markets will emerge as suppliers take advantage of IT to lock in buyers. However, *unbiased* electronic markets will gradually dominate, where all products and suppliers can be evaluated by buyers to make well-informed decisions.

Unbiased markets generally benefit buyers because they are better able to discern the product that best fits their needs. On the other hand, this very benefit to buyers may be a threat to sellers, as they forego the benefits of information asymmetries. Consequently, some industries which were expected to move to unbiased electronic markets have not done so. Possible explanations include the *move-to-the-middle hypothesis* [Clemons et al., 1993] and the *risk-augmented transaction cost theory* [Kauffman and Mohtadi, 2004], which uncover the incentives of market participants to implement biases. Nevertheless, many firms deliberately compete for buyers with market information.

So far, theories of the impact of IT on market structure explain rather specific outcomes. At one extreme, there are theories such as the EMH that predict a move to unbiased electronic markets. On the other hand, there are theories that explain why biased markets and other quasi-market forms may prevail. However, both outcomes are observed in the real world, and it appears that the strategic choices of firms can affect these outcomes. For example, although many online travel agencies have embraced the Internet to offer products and prices from most airlines [Granados et al., 2005], a similar move which would be expected in the mortgage industry has not occurred—at least not to the same extent [Hess and Kemerer, 1994]. With the advent of the Internet, the long-term outcome of the mortgage industry's structure is still uncertain, and it will depend on technical implementation choices of firms in the industry [Wigand et al., 2005].

Our objective is to examine the variations in market outcomes as firms use IT to compete for consumers with market information and provide theoretical explanations for these variations. We start by integrating existing arguments from different theories about why specific market outcomes may prevail. In particular, we use Malone et al.'s [1987] and other authors' numerous arguments about the conditions under which unbiased electronic markets are preferred to biased electronic markets.¹ However, we also use arguments from theories that explain why biased markets may prevail. In other words, while we use existing theory on hierarchies and markets as a theoretical foundation, we focus on the different dimensions of market transformation triggered by IT, once market-based forms are in place.

In addition, we observe that firms have used IT to devise complex strategies to manipulate information that affect more than just the level of bias of their market mechanisms. A more complete characterization of the possible strategies is related to the concept of *market transparency*, which includes the accuracy and completeness of market information, in addition to the level of bias. Therefore, there is an opportunity to extend the theoretical foundations of the impact of IT on market structure, based on real-world observations from recent years, as the evolution of electronic markets is fueled by the Internet.

In this paper, we examine how IT interacts with other forces to facilitate or inhibit a move to transparent electronic markets, and set the stage for future research on other forms of advanced market organization. We use a case research strategy, which is appropriate to answer “how” questions [Benbasat et al., 1987] and uncover process knowledge. In particular, we build theory to answer the following research questions:

- To what extent do we observe a move to transparent markets in different sectors?
- What are the factors and theoretical bases that explain differences in market structure in the presence of IT?

¹ We are indebted to the anonymous reviewers and the senior editor for helping us to appropriately position our theoretical contribution in this research, so as to ensure that the reader will understand how it differs from the work of Malone et al. [1987].

To answer these questions, we leverage the *theory of market design* [Spulber, 1999], which studies the design of market mechanisms that enable trade. This theory provides new perspectives on the possible outcomes of market organization, beyond just the level of bias. We categorize the market design choices that firms make in terms of *informational features* and the *degree of automation*, and use this expanded set of market design dimensions to analyze the IT-driven transformation in the air travel and financial securities markets. Then, consistent with case study methodologies for theory development [Eisenhardt, 1989], we perform a cross-case analysis to develop testable propositions regarding the impact of IT on market structure. Due to the information-intensive nature of these industries, our analysis emphasizes impacts of IT on informational features of markets. However, further theoretical development to explore IT and market structure is appropriate in other dimensions.

We next present two theories—the *theory of electronic markets and electronic hierarchies*, and the *theory of market design*, as bases for construction of a unified theoretical framework for market transparency. In the third section, we analyze the market structure transformation of the United States financial securities markets and the air travel industry. In the fourth section, we perform a cross-case analysis to derive a theoretical framework of the impact of IT on market transparency. We conclude with a discussion and preliminary evaluation of our theoretical contribution and note some related opportunities for future research.

II. THEORETICAL BACKGROUND

We define an *electronic market* as a system that allows market participants to exchange information about prices and product offerings electronically. In this article, *IT* refers to technological artifacts that enable electronic markets, such as Internet, network technologies, and communication technologies. We next describe two theories which provide building blocks to formulate an explanation

of how IT shapes a market's structure: *electronic markets and hierarchies theory* and *market design theory*.

ELECTRONIC MARKETS AND HIERARCHIES

Theories about the impact of IT on organizational forms are rooted in *transaction cost economics*. Coase [1937], in his discussion of the boundary of the firm, suggested that the flow of materials will occur within a firm to the extent that the respective transaction costs are lower than in the price mechanisms of markets. More generally, firms (or hierarchies) and markets are two polar forms of economic activity, while contractual arrangements between firms fall along a continuum from firms to markets, such as electronic integration, long-term contracts, and joint ventures [Zaheer and Venkatraman, 1994].

Building on transaction cost economics, the electronic market hypothesis (EMH) of Malone et al. [1987] predicts that IT will lead to higher use of market transactions in the conduct of economic activity. IT reduces market coordination costs, such as the cost of searching for suppliers, establishing contracts, and buying supplies in the spot market. The EMH also predicts that moves to market-based forms of organization will be gradual; they will not occur all at once.

Malone et al. [1987] state that the first stage will involve movement from electronic hierarchies to *biased electronic markets*. In this stage, suppliers benefit from implementing systems that conceal or distort information about competitors. In the second stage, competitive and legal forces lead to the adoption of *unbiased electronic markets*, where all options for trading are made available. Finally, in the third stage, the proliferation of information in unbiased markets leads to *personalized markets*, with functionality that allows buyers to filter the options available for trading. In this manner, Malone et al. [1987] and other researchers identified the potential impact that IT can have on the informational structure of markets.

It is fair to say that the overall predictions of Malone et al.'s [1987] work were remarkably on target in some industries. One example that especially rings true

is the air travel industry, which involves their predictions about unbiased and personalized markets.

*“In these cases, a final stage may be the development of electronic markets that provide personalized decision aids to help individual buyers select from the alternatives available, what we call **personalized markets** bold added for emphasis]. For example, at least one such system has been developed for airline reservations ... Using this system, travel agencies and corporate travel departments can receive information about available flights with each flight automatically ranked on a scale from 1 to 100. The rankings take into account ‘fares, departure times, and even the value of an executive’s time.’ ... It is easy to imagine even more sophisticated systems that use artificial intelligence (AI) techniques to screen advertising messages and product descriptions according to precisely the criteria that are important to a given buyer ... Air travelers, for instance, might specify rules with which their own **automated buyers’ agents** [bold again added for emphasis] could compare a wide range of possible flights and select the ones that best match that particular traveler’s preferences. A fairly simple set of such rules could, in many cases, do a better job of matching travelers’ preferences than all but the most conscientious and knowledgeable travel agents. [pp. 492-493]*

Despite these theoretical predictions, real world observations point out that IT innovations have not necessarily led to market-based forms of organization in other industries. Hess and Kemerer [1994] analyzed mortgage markets, for example. They suggest that the EMH may need to be reframed because it does not clearly explain the lack of electronic market organization in the industry. With the the Internet, however, industry-wide efforts emerged to implement vertical XML-based IS standards to improve mortgage processing, data exchange and information transparency long the supply chain [Wigand et al., 2005]. Though one could argue that the industry is now more electronic market-like than when Hess and Kemerer examined it, on a relative basis the move to unbiased mortgage markets has not occurred to the extent that it has in air travel markets.

Alternative theories have emerged to explain these industry structure outcomes, which we label *quasi-market theories*. These theories suggest that IT also reduces coordination costs of rather hierarchical contractual arrangements, so relationships with a few suppliers may prevail. Clemons et al. [1993] proposed a *move-to-the-middle hypothesis*. They recognize that IT may not only impact the transaction costs of market coordination, but also the transaction costs of

long-term business relationships, such as monitoring product quality or safeguarding relationship-specific investments. By reducing product complexity and asset specificity, IT reduces the transaction costs of long-term relationships, so buyers may prefer *explicit coordination* with a few suppliers over the purchase of supplies in the spot market.² Wang and Seidman [1995] suggest that, due to negative externalities, it may be optimal for fewer suppliers to join an electronic data interchange system. More recently, Kauffman and Mohtadi [2004] proposed a *risk-augmented transaction cost theory* that is aimed at explaining the market structure effects of demand and supply shocks, such as sudden inventory build-up due to a recession or the loss of a key supplier. They showed that the possibility of shocks impacting large buyers' procurement may lead them to safeguard their profits through vertical or biased relationships, rather than pursuing trade in a market setting.

Moreover, the EMH has not effectively explained the fall in the number of suppliers that occurred in the auto industry in the 1990s [Cusumano and Takeishi, 1991]. Bakos and Brynjolfsson [1993] proposed an interpretation based on the *theory of incomplete contracts*, which posits that not all desired aspects of a trading relationship are contractible. So buyers may limit the number of suppliers to maintain supplier incentives to make non-contractible investments such as quality, responsiveness, and innovation. Hence, the equilibrium number of suppliers may decrease in the presence of IT.

Summary

With the advent of e-commerce technologies and the Internet, we have observed the emergence of new markets and the proliferation of existing ones. Theoretically, this phenomenon can be partially explained with the EMH, which suggests that IT will reduce coordination costs across firms, leading to proportionally higher market-based forms of economic activity. On the other hand, quasi-market theories help explain why biased markets may prevail. When subject to transaction risks such as opportunism, asset-specific sunk costs, and

² *Asset specificity* refers to assets that are specific to the business relationship and that are not easily re-deployable. So investing in these assets becomes a sunk cost attributable to that relationship.

market uncertainties, buyers are held hostage by sellers in the form of biased electronic markets and explicit relationships with a few suppliers. However, by reducing product complexity and asset specificity, IT decreases buyers' vulnerability to these transaction risks, which reduces the viability of biased markets.

This transaction cost-based rationale helps to explain how IT reduces buyer incentives for explicit relationships with one or a few suppliers. However, it does not explain how or why IT may lead sellers to forego the advantages of locking in buyers through long-term agreements. Sellers have a structural incentive to bias markets and distort or conceal information in their favor. So there is a need to develop theory to understand how and why IT leads sellers to increasingly favor transparent electronic markets.

We contribute to the unification and enhancement of prior theory by analyzing the air travel industry and the financial securities industry, which are representative of IT-enabled market transformations in recent years. We leverage our analysis with market design theory, which offers a foundation to categorize the choices that sellers make which may affect market structure. In particular, this theoretical perspective examines different types of selling mechanisms and the conditions under which sellers will select one type over another. Before presenting our analysis of these industries, we provide a review of different market design choices and how they are influenced by IT advances.

POSSIBLE OUTCOMES OF MARKET STRUCTURE

In competitive markets an exogenous mechanism selects prices that establish equilibrium between supply and demand. The related theory—*market design theory* or *market microstructure theory*—attempts to illuminate this “black box” by taking an alternative view [Madhavan, 2000]. *Market microstructure* is defined as the set of market participants, institutions and mechanisms that enable trade. It emphasizes that firms make explicit decisions to select trading prices and coordinate transactions that support exchange. Spulber [1999, p. 7] states that “[f]irms create and operate markets: setting prices, carrying out transactions, producing and distributing information, and forming and monitoring contracts.”

Equilibrium outcomes are aggregate results of the individual firms' actions, including choices affecting market microstructure.

The theory of market design focuses on the economic consequences of a trading mechanism's design. It has been extensively applied in the context of financial markets to understand how electronic trading influences liquidity, efficiency, and the distribution of wealth [Clemons and Weber, 1990; Schwartz, 1995], and there is a growing body of literature on the design of electronic markets, grounded on auction theory [Anandalingam et al., 2005].

IT, Electronic Markets, and Market Design

Firms use IT to design the informational features of their selling mechanisms and to automate them. (See Table 1.) The *degree of automation* of a trading mechanism is determined by transaction efficiency and its temporal and geographical characteristics [Schwartz, 1995]. For example, Internet-based electronic markets enable efficient around-the-clock trading across national boundaries. In addition, automation allows sellers and buyers to trade without the intervention of intermediaries. *Informational features* of market design include market transparency, price discovery, and trading protocols. We now discuss in more depth how IT influences these informational features in the context of electronic trading.

Market transparency specifies the extent to which information is made available to market participants, including pricing, product, and supplier information [Granados et al., 2005]. Market transparency is negatively affected by sellers' decisions to bias, conceal, or distort information. A *biased market* is defined as a market where product and price information from all sellers is not presented equitably. A market that displays only prices but lacks information about product characteristics is not fully transparent because information is incomplete. On the other hand, a market that distorts information is not fully transparent because the information is inaccurate. Incomplete or distorted information may be driven by intentional market designs of sellers, or by technological imperatives that limit the quality and quantity of information that can be made available. We define *opaque markets* as those where information is

Table 1. Market Design Dimensions and Impact of IT

MARKET DESIGN DIMENSIONS	DESCRIPTION	IMPACT OF IT
<i>Informational Features</i>		
Market Transparency	Availability and accessibility of market information.	Increases potential for complete, accurate, and unbiased market information
Price Discovery	Process by which market prices are established	Enables innovative and dynamic mechanisms
Trading Protocols	Transaction process and rules	Increases flexibility to set trading rules
<i>Degree of Automation</i>		
Efficiency	Speed and cost of transactions	Increases efficiency
Reach	Frequency of transactions and geographical reach	Increases reach potential
Reliance on Intermediaries	Degree of intermediation	Enables electronic intermediation and direct trading
Source: Adapted from Madhavan [2000]		

incomplete or distorted. For example, Hotwire (www.hotwire.com) is an online travel agency that offers last-minute fares for multiple airline, showing a low level of bias. However, it does not show the airline or itinerary until after purchase, so we characterize it as an opaque market mechanism.

E-commerce technologies increase the potential for market transparency. In turn, sellers strategically decide whether to capitalize on this potential in two ways. First, they can make choices regarding the information to be disclosed to buyers through their market mechanism, such as their own Internet portal or an electronic exchange in which they have decision-making power. Second, they can make strategic decisions to trade in a market based on its information disclosure rules. Large market participants often avoid trading in electronic markets that require broad identity disclosure because it provides signals about their cost structure [Zhu, 2004] or their motivation to trade [Clemons and Weber, 1990; Madhavan, 2000].

But buyers generally prefer market transparency. This is because they can better ascertain their product valuation and select the best product and supplier

at the best price. Market transparency benefits buyers in three ways. (See Figure 1.) First, search costs decrease as more information is made available at no additional cost. For example, through the Internet, major online travel agents (OTAs) such as Orbitz, Travelocity, and Expedia now provide immediate and inexpensive access to tables with multiple combinations of air carriers, flight itineraries, and ticket prices. By purchasing a ticket via these OTAs, consumers can evaluate multiple alternatives and act as their own travel agents.

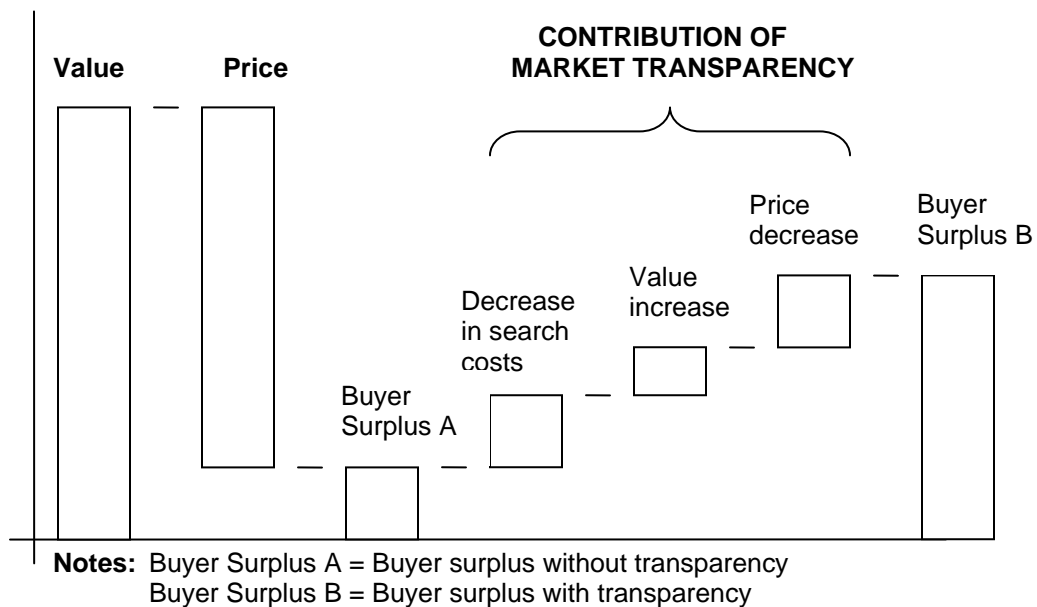

Figure 1. Contribution of Market Transparency to Buyer Surplus

Second, the value of a purchase increases if the consumer discerns product characteristics of existing alternatives with higher precision, resulting in more accurate product valuation [Hasbrouck, 1995]. In financial markets, for example, Internet brokerage firms are able to provide instantaneous and detailed information about a stock, which enables a more accurate valuation by the investor.

Third, information may become available that allows a consumer to transact at a lower price for a given product. Stigler [1961] showed that a lower price may result if search costs are reduced such that a lower market price is discovered. However, there are some situations in which buyers may prefer less market transparency. For example, in business-to-business markets, high-demand

buyers may express concerns about sharing too much information about their demand forecasts, lest an electronically linked supplier will exploit that information and turn prices against them [Kauffman and Mohtadi, 2005].

Price discovery, the process by which market prices are established, is another important aspect of market design. Price discovery involves the process by which latent demand and supply result in realized market prices and trade volumes [Madhavan, 2000]. In some markets, by obtaining details about the trading process, buyers and sellers are able to discover their reservation prices. For example, in financial markets transaction history provides clues about demand and supply pressures, which influence the prices at which buyers and sellers are willing to transact [Pagano and Roell, 1996].

Auction theory is related to price discovery in electronic market design [Anandalingam et al., 2005]. Electronic market mechanisms such as double auctions have a *dynamic* price discovery process: every bid by buyers, sellers, or intermediaries is a signal to determine transaction prices. Other market mechanisms, such as posted prices, are more *static*. ITs such as the Internet enable the creation of novel and dynamic mechanisms, increasing the potential for price discovery. In turn, sellers make choices regarding market designs along a continuum from static to dynamic market mechanisms. For example, Internet-based electronic auctions of airline tickets have enabled markets for distressed inventory of seats close to flight departures [Klein and Loebbecke, 2003].

Trading protocols represent the rules of trading and transactional exchange. Protocols are often the result of ongoing business practices and transactional norms. They may reflect government regulations to ensure fair trading practices, market participation fees and other fixed transaction costs for the market participants. Advanced ITs enable innovative and flexible definition of transaction protocols. For example, the practice of 24-hour electronic trading in financial markets is now possible thanks to Internet technologies. On the Internet, a change in trading rules may require a small, immediate, and inexpensive change in a Web site's design that will become rapidly available to all participants.

IT and Market Design Trade-offs

Together, these informational features of market design influence market performance. However, there are trade-offs to be made, because changing a market's design in one dimension may affect it in another [Levecq and Weber, 2002]. In the market transparency dimension, suppliers and intermediaries are commonly faced with the trade-off between the benefits of a more transparent market to attract buyers and the losses that may be incurred by releasing private information. Though market transparency increases demand by attracting buyers, it may put seller profit at risk due to better informed buyers [Porter, 2001].

In the price discovery dimension, sellers face the decision to post fixed prices or negotiate. While negotiation allows effective price discovery, there are information and negotiation costs that may deter buyers [Riley and Zeckhauser, 1983]. There is also a trade-off between selecting a fixed price versus an auction mechanism. While an electronic auction may attract buyers through effective price discovery, it may also hurt seller revenues as buyers enjoy higher levels of price transparency. Therefore, market design decisions that buyers, sellers, and intermediaries make depend on the evaluation of these trade-offs.

We contend that IT transforms these market design trade-offs, such that the long-term expected aggregate outcome of sellers' market design decisions will change. In the next section, we examine this process for air travel and financial securities, which have gone through significant IT-driven changes in the dimension of market transparency. Based on these mini-cases, we develop a theoretical framework of the impact of IT on market structure.

III. WITHIN-CASE ANALYSIS: AIR TRAVEL AND FINANCIAL SECURITIES

The robustness of a theoretical model is largely based on its ability to explain different kinds of outcomes that are observed for a given phenomenon. We seek to explain the extent to which transparent electronic market mechanisms prevail across industries. Some industries make it to that point sooner, while others arrive later (and possibly not at all). Thus, since our goal is to develop an

effective *variance theory*, we selected the air travel industry and the financial securities industries for our study, because they exhibit significant variation in the degree of bias, accuracy, and completeness of market information. We observe that since the advent of the Internet, these industries have made strong moves towards higher market transparency, but the sources and extent of this transformation differ by industry sector.

In this section, we present two mini-cases of the market transformation of air travel services and the financial securities trading. The findings that we present summarize our extensive *within-case* analysis on these industries based on prior research experience, current press releases, academic journals, specialized industry publications, and interviews with industry experts.

CASE 1: ELECTRONIC MARKETS FOR FINANCIAL SECURITIES

Financial securities have been traded electronically for decades in markets such as the New York Stock Exchange (NYSE). Recently, Internet technology has created new opportunities for electronic transactions in both business-to-business (B2B) and business-to-consumer (B2C) electronic markets. In this mini-case, we examine the forces that, together with Internet technology, have resulted in new market mechanism designs for the trade of financial securities. We focus on the differences that have emerged in the electronic trade of bonds and stocks, despite the fact that the emergence of Internet technology exerted simultaneous influence on both industries.

The Institutional Markets for Equities and Bonds

The markets for fixed income securities in the United States have been the province of a group of powerful investment banks that have exercised considerable market power. The result for private corporations and public organizations that wish to issue bonds to obtain capital in the primary market, as well as for investment management firms and individuals that wish to trade bonds in the secondary market, is that they have not been able to benefit from some of the efficiencies that are normally associated with the equities market. Equity markets vary in all design dimensions, namely market transparency, price discovery, and trading protocols [Levecq and Weber, 2002; Madhavan, 2000]. In

the market transparency dimension, designs vary in the time and extent of the information, and it is commonly intervened by regulations to ensure efficiency and fairness. For example, U.S. regulations require that transactions be reported within 90 seconds of the transaction, compared to 90 minutes in the London Stock Exchange. In the price discovery dimension, there are auction markets which are order driven, that is they match buy and sell orders continuously. On the other hand, there are call markets which are quote driven, that is they match prices based on bid and ask quotes from a market maker. Transaction protocols determine other conditions of trade such as the immediacy and the priority of order execution.

Instead, for bonds, up until 1997 there were only a few viable private electronic markets that permitted bond issuance and trading, but not many (e.g., Bloomberg, Morgan Stanley, First Boston Corporation, etc.) [Bond Market Association, 1997a]. During the 1990s, there were contentious public policy debates related to the “opaqueness” of the bond market [Bond Market Association, 1997b]. Prices were difficult for investors to see because trade-related information was guarded by the market-making investment banks. They stalled the move to newer market designs that permit fuller market transparency. This practice is facilitated by the inherent diversity of bonds relative to equities. Firms with one or two issues of stock (common and preferred) may have numerous bond series, reflecting different coupon rates and the maturity of the debt. Therefore, there may be millions of fixed income securities compared to a few thousand shares [Allen et al., 2001].

During the 1990s, the impacts of new e-commerce technologies began to be felt, as trading and competition started outside of the traditional trading floors [Economides, 2001]. Prior to gaining authority as a primary issuer of bonds like investment banks, commercial bank J. P. Morgan innovated with a dial-in screened-based bond issuance market for “vanilla debt” involving the most well known corporate names. Although the system, Capitalink, did not succeed, it nevertheless sensitized the market to the possibilities that technology held for transforming market design in support of bond issuance. Later, during the growth of the Internet, other investment banks, government agencies and

entrepreneurs implemented technology-based approaches to trade various kinds of fixed income securities [Bond Market Association, 1998-2003]. A number of players put together different types of electronic markets, including auction systems, inter-dealer systems, multi-dealer systems, single-dealer systems, and cross-matching systems [Bond Market Association, 2003]. Examples are MarketAxess (www.marketaxess.com) for bond trading among institutional investors and the Bloomberg Municipal System (www.bloomberg.com).

Despite recent innovation in the design of market mechanisms for bond trading, the effect of electronic markets for bonds has not had the same lasting effect as in equities markets. Because of the existence of single-dealer markets which use the Internet as a means to involve their own institutional investment clients, there is still bias in the bond market. Some of these systems are reachable via the Internet, while others are only available through an intermediary, Bloomberg Inc., the preeminent quote vendor and financial news network [Bond Market Association, 2002]. They include Lehman Brothers (www.lehmanlive.com), Credit Suisse First Boston (www.csfb.com), Merrill Lynch (www.ml.com), Morgan Stanley (www.morganstanley.com) and J. P. Morgan (www.jpmorganexpress.com), among others, and reflect the fact that the prior “oligopoly players” are still using the new technologies to make markets for bonds based on client relationships, instead of a full-fledged market-based approach.

However, there have been significant advances in market transparency and fairness in the trade of bonds thanks to Internet technology. Kauffman and Lu [2005] analyze the structure and performance of digital bond markets in the U.S., and noted the path-breaking range of their innovations. The Internet has provided a basis for pushing the capabilities for bond exchange beyond what was historically observed, when bonds were largely traded in biased electronic markets. In addition, it is clear that with this new technology has come a greater impetus for competition around new and enhanced market designs. But the emergence of transparent electronic markets for bonds has been slowed down by their own nature. Bonds are not as commodity-like as stocks. So considerations necessary

to an effective market process may still be affected by the inherent complexity of bonds, which may explain why only 10% of corporate bonds were electronically traded in 2000 [Allen et al., 2001].

Bond and Equities Markets for Individual Investors

In the 1990s, Internet-based trading mechanisms for individual investors also emerged, such as E*trade (www.etrade.com), Charles Schwab (www.schwab.com) and Ameritrade (www.ameritrade.com). Internet brokers allow individual investors to trade stocks electronically with low transaction costs. In addition, they provide timely market updates and archives of research reports. By providing Internet-delivered market information, automated trading, and low transaction costs for individual investors, these companies succeeded in an industry that had historically been controlled by large, powerful players.

Despite the emergence of these discount brokers, the niche for full-service brokers remains. In the equities markets, there is still a need for brokers that provide value-added investment services to individual consumers. In particular, given the overload of information for a given stock or group of stocks, it may be economically justified for investors to pay for information brokerage services that increase the level of market transparency even further, at a fee. Hence, there remain opportunities for product differentiation and market segmentation, which make hierarchical forms and biased markets feasible. For example, wealthy individuals often prefer one or two investment services firms to manage their investments.

The rise of B2C transparent electronic market mechanisms in the stock market presents similar trends as in the B2B sector. On the other hand, bond trading remains in the hands of professional trading firms to a greater extent. Web-based technologies for the trade of financial securities are still evolving, but the product complexity of bonds limits the development of transparent bond markets.

CASE 2: MARKETS FOR CORPORATE AND LEISURE AIR TRAVEL

Online travel sales increasingly threaten the market-making position of traditional travel agencies. In 2003, about 40% of U.S. airline tickets were sold via the Internet [Airline Business and SITA, 2003]. An important driver of this

trend is the increased level of market transparency facilitated by technologically-innovative and customer-friendly online travel agencies (OTAs) such as Orbitz (www.orbitz.com) and Expedia (www.expedia.com). In the same year, approximately 20% of U.S. corporate travel revenue was managed online [Phocuswright, 2003]. These are both significant amounts relative to the overall cross-industry percent of retail sales through the Internet, which was short of 2% [U.S. Census Bureau, 2004]. In this mini-case, we explore the accelerated IT-driven move to markets in the corporate and leisure air travel markets.

B2B Air Travel Markets: Airlines and Travel Agencies

Travel agencies take advantage of the high complexity of airline prices and product descriptions to act as *information brokers* by simplifying offers to corporate and leisure travelers [Clemons and Row, 1991]. The information brokerage role performed by travel agencies was strengthened in the 1980s with the development of computer reservation systems (CRS) technology. This technology was developed by airlines after deregulation of the industry in 1978 to compete effectively. CRS terminals were typically installed at travel agency locations based on long-term contractual sales agreements. Through these contracts, agencies were locked in to an airline or small set of airlines depending on the CRSs installed [Copeland and McKenney, 1998]. By 1983, 80% of tickets were sold by travel agencies through CRS terminals.

Due to the biased nature of CRS contracts between airlines and travel agencies, allegations emerged suggesting that automation of airline ticket distribution had resulted in an anti-competitive market environment. In June 1983, the government concurred and intervened, ordering CRSs to provide data on their flights and ticket prices to competitors, avoid discriminatory fees, and eliminate screen biases that favored the position of product offers for the airline owner or owners of a CRS.

While the level of bias decreased in the market for airline tickets due to these new laws, travel agencies still had the ability to conceal and distort information from consumers [Levine, 1987]. CRSs reduced product complexity for travel agencies, but travelers remained dependent on their relationship with the

agencies to get the best travel offer at the best price. Globalization and extension of the functionality of these CRSs to include hotel and car reservations led to global distribution systems (GDSs), which allowed airlines and travel agencies to further consolidate their competitive positions by offering complete and timely information to the traveler for air transportation, ground transport, and lodging.

B2B Air Travel Markets: Corporate Travel

Corporate travel accounts for approximately 55% of total air travel passengers [PhocusWright, 2003]. Historically, brick-and-mortar travel agencies have added value for business travelers by searching for the best prices and services. In addition, they aggregate demand for corporations to negotiate lower prices and value-added service with airlines [Clemons and Row, 1991], contributing to the segment of the industry known as *managed business travel*.

Corporate travel customers typically have a need for special services. Frequently, their plans change and they need timely attention to change their travel itineraries. In addition, travel itineraries are sometimes complex, involving more than just a simple round trip between two cities. Therefore, the complexity of corporate travel needs is an opportunity for traditional travel agencies to provide *service brokerage* between airlines and corporations.

Rosenbluth Travel is a case in point [Clemons and Row, 1991]. Rosenbluth Travel developed an information system that consolidated travel offers from several major CRSs to provide value-added service to its corporate travel customers. The company gained competitive advantage by improving efficiency for its customers, through a wider variety of product offers tailored to specific customer needs. In addition, the system provided complete and accurate information about prices and alternative itineraries, both current and historical. Soon competitors replicated this technological innovation, but at that point Rosenbluth travel had consolidated its position in the B2B travel agency services market worldwide.

Despite technological advances that allow corporate travelers to perform transactions directly with airlines, travel agencies continue to perform an added-value role in the business segment of air travel. This may explain why

transparent OTAs have successfully penetrated the leisure and unmanaged business travel markets (see below), but they are just beginning to make inroads in the managed business travel segment. In 2003, 20% of U.S. corporate travel was sold online, compared to 40% for the industry as a total. Due to the service requirements of business travelers, there may be a limit to the value that can be extracted from Internet-based reservation-making [Chircu and Kauffman, 2001]. Nevertheless, recently major OTAs have developed strategies to further penetrate the corporate travel business segment, and brick-and-mortar travel agencies such as Carlson Wagonlit Travel are being forced to respond with their own Internet-based market mechanisms that offer the lowest prices in the market [Reinan, 2004].

B2C Air Travel Markets

In the 1980s and 1990s, travelers typically built relationships with a preferred travel agency to book and purchase airline tickets. Soon the development of the Internet enabled new B2C distribution channels in many industries, and the air travel industry was no exception. In the 1990s, multiple online travel agencies (OTAs) emerged to offer travel products to consumers over the Internet, threatening the information brokerage role of travel agencies.

The design of market mechanisms in these OTAs varied [Klein and Loebbecke, 2003]. Most OTAs offered travel options based on list prices. However, others attempted innovative price discovery mechanisms. For example, TravelBids introduced auctions from the consumer's side, where consumers would post an itinerary and travel agencies would bid for the trip based on their inventory availability and prices. Priceline.com introduced a *name-your-own-price* mechanism that resembles a sealed-bid auction, where consumers make a bid for a trip and only after purchase the airline and specific itinerary is revealed. Some OTAs were designed to be transparent, such as Expedia (www.expedia.com), which displays itineraries and prices from multiple airlines based on a trip search request. Others were designed to be opaque in either product, price, or supplier information, such as Priceline.com (www.priceline.com) and Hotwire (www.hotwire.com). Opaque OTAs

compensate the consumer for this lack of market transparency with lower prices.

In an attempt to increase revenues, some OTAs initially created biased selling mechanisms. Similar to GDSs in their inception, OTAs such as Travelocity (www.travelocity.com) and Expedia (www.expedia.com) negotiated agreements with airlines to favor their itineraries in a screen display, resulting in biased offers to consumers. In addition, airlines reintermediated the online travel sector by developing their own Web sites to offer airline-specific itineraries.

Recently, the airline industry made a bold move to reintermediate the online travel sector. Five major airlines introduced Orbitz (www.orbitz.com) in 2001, claiming that it was the most transparent OTA. Orbitz was designed with a state-of-the-art Web-based system to offer as many products as possible for a travel request. In addition, Orbitz developed preferred agreements with airlines and distributors that guaranteed their claim to give the lowest published fares anywhere [Salkever, 1999]. Soon other OTAs followed Orbitz's competitive move for higher market transparency [Granados et al., 2005]. Expedia and Travelocity have retracted from their strategy to bias fare searches in favor of specific airlines, and Hotwire and Priceline.com added transparent mechanisms to their opaque product offers. Nevertheless, after only two years, Orbitz was able to consolidate its position as a leader in the OTA market.

IV. CROSS-CASE ANALYSIS

In this section we perform a cross-case analysis that compares and contrasts the degree to which B2C and B2B air travel and financial securities markets have become transparent, the influence of IT in this process, and its interaction with other relevant forces. We first provide some preliminaries, including some assumptions for our analysis. Then, we present a theoretical framework that emerged from this analysis, and the related propositions. Finally, we discuss the findings and the implications for IT strategy.

PRELIMINARIES AND ASSUMPTIONS

Advances in IT increase market design alternatives and add complexity to a firm's evaluation of market design trade-offs. In the Internet environment, while

traditional players have created electronic market mechanisms to sell and purchase products, non-traditional market-makers have also emerged with new and innovative market mechanisms. Examples covered in our mini-cases are Capitalink in financial markets, and Priceline.com in air travel, among others. The mini-case studies of the air travel and financial Internet markets suggest that market design options for market participants have multiplied, yet there is an increased preference for the use of transparent market mechanisms. In the following cross-case analysis, we will develop propositions to explain how buyers and sellers favor transparent electronic markets in the presence of IT, despite an explosion of market design options available. To make our analysis tractable and to set the boundary conditions for the application of our findings, we make the following assumptions:

- An industry is a closed economic system, so structural market outcomes are not influenced by developments in other industries.
- The impact of IT on firms' internal operations does not affect market structure. We will later relax this assumption and discuss the implications.
- The benefits of transparent electronic markets are evident for buyers (i.e., buying firms or consumers).
- Sellers (i.e., suppliers or intermediaries) have the ability to design and implement their own market mechanisms, or to strategically trade in existing electronic markets.
- Sellers have incentives to maintain information advantages in the form of bias, distortion, or concealment of information.

How then can the aggregate IT-enabled strategies of sellers result in the dominance of transparent markets? What are the forces that drive this process? Likewise, what are the inhibiting forces? Once economic organization is market-based, it can vary in several dimensions, including the degree of bias and opaqueness. We argue that IT alone does not eliminate the incentives sellers have to implement biased or opaque markets. Despite IT advances, sellers still have the choices to introduce bias and opaqueness, or to compete for buyers with market information. Therefore, a move to transparent markets can be

viewed as a process by which the market design trade-offs of most sellers evolve to favor and implement transparent market mechanisms.

THEORETICAL FRAMEWORK

In the following analysis we show how markets with unbiased, complete, and accurate information tend to prevail despite the explosion of IT-driven market design options for sellers. We develop a theoretical framework of the move to transparent electronic markets by contrasting and comparing the status of market structure in the financial securities and air travel industry sectors. (See Figure 2.)

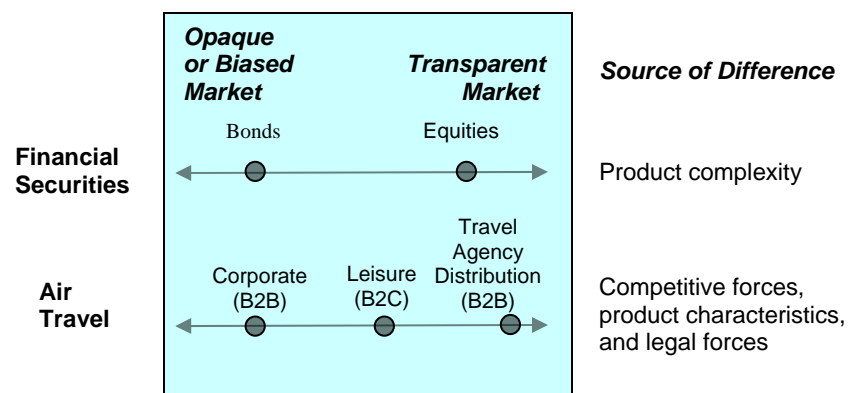

Notes: (1) Transparent e-markets are less dominant for bonds than stocks due to the higher product complexity of bonds. (2) Price competition in the travel industry has facilitated the move to transparent e-markets. However, differentiation strategies possible in corporate travel markets have inhibited this move. Service-oriented corporate travel products make biased and opaque markets competitive, in part due to the non-digital nature of customer service. (3) Travel agency distribution became transparent due to regulatory measures that curbed anti-competitive behavior.

Figure 2. Structure of the Air Travel and Financial Securities Markets

To characterize the key ideas up front, we offer the following brief explanation. The driving forces in the move to transparent electronic markets are IT and forces that facilitate competition and electronic trade. These forces lead to markets with accurate, complete and unbiased market information. Next, we explain how these forces interact to favor transparent markets. (See Figure 3.)

From Electronic Hierarchies to Electronic Markets (Link A)

The EMH suggests that IT facilitates the move to market-based electronic trading by diminishing market coordination costs. Figure 3 shows how the theory

of electronic hierarchies and markets relates to our theoretical framework.

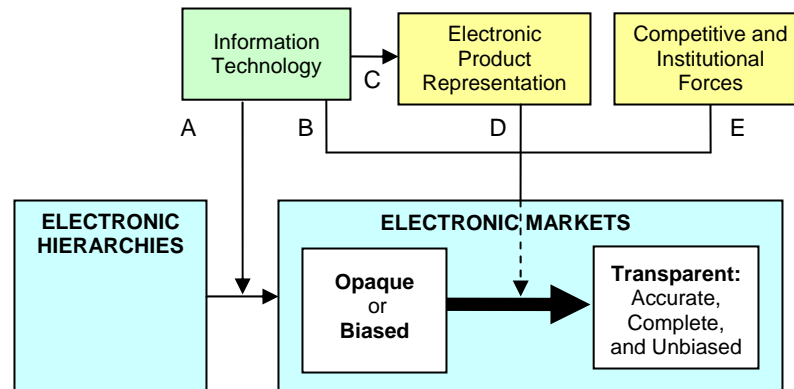

Note: Link A represents the impact of IT on the shift from electronic hierarchies to electronic markets, or the EMH. Although Link A represents the core focus of the EMH, we emphasize that Malone et al. [1987] also discussed and made predictions about the subsequent stages of market structure in the dimension of bias, reflecting the roles of some of the other links in the figure. Link C shows the impact of IT on electronic product representation. Links B, D and E suggest that IT, electronic product representation, and competitive and institutional forces help together explain the variance in market transparency levels across industries.

Figure 3. Theoretical Framework on the Move to Transparent E-Markets

IT-Driven Market Transparency (Link B)

IT enables transparent market design choices for sellers to attract buyers. First-movers will benefit most from proprietary technological innovations, but competition is likely to follow. We observe this phenomenon in both air travel and financial securities, where new technologies have enabled competition for customers with market information. Representative examples are Rosenbluth and Orbitz in air travel and Capitalink in the bond market. These firms took advantage of e-commerce technologies to increase their customer base by developing technologies to process and offer market information beyond common industry practices. This leads to our first proposition:

- **Proposition 1 (The IT and Market Information Proposition):** *Sellers will deploy and develop IT to compete with market information.*

The IT and Market Information Proposition suggests that firms will use IT to innovate with transparent market mechanisms, beyond the traditional low cost and product differentiation strategies. We observe that in all industry sectors of

air travel and financial securities markets, the move to transparent electronic markets started with innovations to compete with market information. As sellers automate their processes and take advantage of e-commerce technologies, they will increasingly compete for buyers by offering product and price information that informs their purchase decisions.

This proposition expands and complements the transaction cost-based premises of electronic markets and hierarchies theory. It suggests that a milestone necessary for a move to transparent electronic markets is the use of IT for revenue-generating strategies. More generally, when innovative information brokerage strategies begin to occur, therein lies the foundation for a move from biased and opaque markets to transparent electronic markets. However, this proposition falls short of suggesting that IT alone leads to the dominance of transparent markets. Incentives may remain for most sellers to maintain non-transparent selling mechanisms. For example, quasi-market theories suggest that biased market mechanisms may prevail even in the presence of IT. More generally, although IT enables new market designs, the trade-off between the informational advantage of biased and opaque mechanisms and the increased revenues from transparent mechanisms may still fall in favor of the former. This may explain why some markets have remained biased despite the presence of advanced ITs. We contend that, together with IT, other conditions and forces must be present in order for transparent market mechanisms to prevail.

IT and Product Characteristics (Links C and D)

We define *electronic product representation* as the ability to describe a product through an electronic medium. The air travel and financial securities markets suggest that ITs that reduce product complexity and that digitize product characteristics influence electronic product representation, which in turn has an impact on sellers' market design choices.

IT and Product Complexity. Bonds exhibit a high level of product complexity relative to other financial securities, which may explain why the proliferation of transparent bond market mechanisms has been slower than in equity markets. IT-driven pressure to adopt transparent market mechanisms is structurally weakened

by the complexity of bonds, which still makes biased and opaque bond markets viable.

Bonds are complex for both institutional and individual investors. Therefore, bond trading is still mainly in the domain of professionals who make complex decisions over the many different risk profiles offered by fixed-income securities. Individual investors still lack automated brokerage services that provide bond investment recommendations. This relative lack of IT-based automated mechanisms leads to the persistence of long-term relationships between individual investors and investment services firms for bond trading.

More generally, we contend that the higher the level of product complexity, the less is the pressure that IT exerts on suppliers and intermediaries to adopt transparent market mechanisms. This is because firms can provide value-added services to simplify product complexity for the buyer. This opportunity for *service differentiation* decreases the need to seek innovative market designs. Buyers face uncertainty and opportunism risks that suppliers and intermediaries can mitigate by offering long-term business relationships, resulting in viable biased or opaque markets.

However, by reducing product complexity, IT may in turn reduce the competitive viability of opaque and biased market mechanisms. For example, motivated by the complexity of airline schedules and prices, airline owners of CRSs originally enjoyed economic benefits by controlling and selling airline schedule and price information through preferential agreements. However, travel agencies such as Rosenbluth developed technologies to aggregate, filter and simplify complex information displayed by CRSs, to the benefit of corporate travel customers [Clemons and Row, 1991; Granados et al., 2005]. In response, CRSs have become more open and service-oriented.

Digital Product Characteristics. Products can be classified based on the ability to represent them electronically. At one extreme are information goods, which are digital in nature and can be easily represented electronically. At the other extreme are physical goods such as clothes, which defy accurate electronic representation. We contend that the along this continuum of product types, the

more a product can be described digitally, the higher are the chances that transparent market mechanisms will prevail. Our rationale is two-fold, based on our observations of the air travel and financial markets. First, the relative success of OTAs was driven by the user-friendly and consistent display of product offers from multiple airlines, including the itinerary, number of stopovers, and prices. More generally, since transparent market mechanisms offer product options from multiple suppliers, they require more processing, flexible tailoring, and manipulation to provide equitable, accurate, and complete information. Digital product representation reduces these costs of information processing, so the cost reduction benefits are relatively higher for transparent electronic markets.

Second, both equity and leisure travel products are relatively easy to convey electronically, which allowed non-traditional firms such as E*trade and Expedia to develop Web sites with innovative market information displays. Upon their entrance, traditional firms were pressured to reintermediate the online market with their own transparent mechanisms. More generally, the ease of representing products electronically makes it more difficult for sellers to distort or conceal information, because there is competitive pressure from other players who can also provide this information at a low cost.

It follows that IT artifacts which enable digital representations of a product favor a move to transparent markets. CRS technology in the air travel industry translated the complex information on airline schedules and service so that travel agencies could better translate this information to travelers. Later, this same technology was used by online travel agencies to develop user-friendly interfaces for travelers to make their own purchases. On the other hand, the Internet allowed discount equity brokers to develop user-friendly representations of stock market information for individual investors. This leads to our second proposition:

- **Proposition 2 (The IT and Electronic Product Representation Proposition):** *IT that enables effective electronic product representation favors a move to transparent electronic markets.*

The IT and Electronic Product Representation Proposition suggests that, on a relative basis, industries where IT advances make it easier to electronically

represent a product will make a faster move to transparent electronic markets. Our rationale is both transaction-cost based and revenue-based. Since transparent markets require more information processing capabilities than biased and opaque markets, if IT reduces product complexity or increases the ability to represent products electronically, the respective cost reduction is relatively higher for transparent market mechanisms. On the other hand, IT that facilitates electronic product representation makes it difficult for a seller to distort or conceal information. This is because there is competitive pressure from other sellers who can provide accurate and complete market information.

Competitive and Institutional Forces (Link E)

The air travel and finance industries provide evidence that competitive and institutional forces favor a move to transparent electronic markets.

Competitive Forces. In U.S. air travel, it is common to observe price competition among airlines since the deregulation of the industry, particularly in leisure markets which have been commoditized. In the absence of the ability to compete effectively with differentiation strategies, competition by innovative and transparent OTAs has emerged successfully in the leisure segment. However, the competitive forces that favor transparent electronic mechanisms for leisure travel are mitigated in corporate travel due to its service-oriented nature. The market power that corporations obtain through consolidation of demand by travel agencies and the need for value-added services (e.g., handling complex trips and time-sensitive itinerary changes) reduces the pressure on corporate travel providers to compete with market information. Therefore, opportunities for product differentiation make biased and opaque market mechanisms viable in corporate travel.

In competitive environments, firms have an incentive to adopt innovative market designs as strategies for differentiation, rather than fuel losses from price competition. Facing the choice of implementing an IT-enabled transparent mechanism or competing on price to attract buyers, many firms will prefer to compete for buyers with market information. Potential incremental benefits from a biased or opaque market mechanism will not offset the potential losses that

price competition brings. In addition, implementing transparent market mechanisms increases pressure to eliminate price discrimination. For example, the Internet has allowed consolidation of international financial and air travel markets, diminishing the ability of firms to price-discriminate based on regional and national borders [Economides, 2001; Reuters, 2004].

In summary, competitive forces tend to make transparent market mechanisms more viable than biased and opaque ones. Sellers with market power may be in a position to lock in buyers through biased and opaque market mechanisms. In contrast, under the threat of *price competition*, differentiation with market information may be a preferred strategy.

Institutional Forces. It follows that institutional forces that promote a competitive environment also favor a move to transparent markets. Some institutions explicitly lobby to prohibit market bias and opaqueness, such as consumer protection agencies, industry lobbying groups, and regulators that prohibit predatory behavior by firms with market power. In the 1980s the airline owners of GDSs gave preferential treatment to their own travel options in screen displays, so regulations were created to prohibit these practices of market bias. Moreover, regulations were introduced that required owners of GDSs to share sales information with other airlines, allowing competitors to have complete and accurate information about each other's products, prices, and sales history.

Institutional forces that discourage anti-competitive behavior indirectly lead sellers to collectively support transparent electronic markets. In particular, in the presence of regulations that make explicit collusion illegal, sellers may prefer transparent electronic markets so they can tacitly collude and avoid losses from price competition [Varian, 1999; Campbell et al., 2005]. This theoretical impact of institutional forces that discourage explicit collusion has been observed in financial and air travel markets. Christie and Schultz [1995] found that traders tacitly colluded to avoid trading at the odd-eighth quotes, increasing the average spread. The study prompted an investigation by the Securities and Exchange Commission, resulting in a \$1 billion dollar settlement with investors to drop pending lawsuits. Similar competitive and legal forces may also explain why,

despite the risk to their profits, major U.S. airlines reintermediated the Internet B2C air travel market with Orbitz, which provided transparency to the market beyond what had been observed so far. The aforementioned analysis leads to the following proposition:

- **Proposition 3 (The Competitive Forces Proposition):** *In the presence of price competition and laws that prohibit explicit collusion, sellers will favor and implement transparent electronic market mechanisms to collude tacitly.*

The Competitive Forces Proposition suggests that in the presence of both price competition and anti-trust laws, the ability of sellers to monitor each other with transparent market mechanisms brings more benefits than the gains from biased and opaque market mechanisms.

The Move to Transparent Electronic Markets

So far, we have shown how IT favors transparent market mechanisms over biased and opaque ones in two ways. First, IT enables new and innovative ways to compete for buyers with market information, increasing the potential for market transparency (Link B). Second, IT increases the ability to disseminate market information electronically, by enabling digital representation of products and reducing the complexity of product descriptions (Link C). However, these impacts of IT do not eliminate all incentives sellers have to implement biased market mechanisms. Competitive and institutional forces further diminish the attractiveness of biased or opaque market mechanisms. This leads to:

- **Proposition 4 (Transparent Electronic Market Proposition):** *In competitive industries where products can be effectively represented electronically, IT will lead to the dominance of transparent electronic markets. The absence of any of these factors inhibits the move to transparent electronic markets.*

Based on the conditions stated in the Transparent Electronic Market Proposition, the theory of transparent electronic markets predicts the industry sectors where the IT-driven dominance of transparent electronic markets will be observed. We contend that competition and product characteristics that favor electronic trading are sufficient to tilt the trade-off between the benefits of biased

or opaque market mechanisms and transparent market mechanisms in favor of the latter. Other industries with any of the conditions absent may still experience a move to transparent markets, although at a lower pace or to a lesser extent than those where all conditions are present.

DISCUSSION

In this section, we discuss the findings from the cross-case analysis and the implications for practitioners and researchers.

Discussion of the Findings

In our effort to build a unified theoretical framework, we were originally motivated by an in-depth analysis of the air travel industry [Granados et al., 2005] to look at the existing theory more deeply, and to see what we could do to explain things that didn't seem to match up with prior research. We were especially interested in the decision of U.S. airlines to invest in the development of technology to launch a transparent online travel Web site, with unbiased, complete, and accurate information. As we expanded our analysis to include other industries, we obtained consistent observations of deliberate strategies by firms to compete with market information, despite the risks to their profitability.

Our theoretical propositions—and our unified theoretical perspective, based on Malone et al. [1987] and other related literature—are the outcome of inductive and deductive thinking to explain how IT leads to transparent electronic markets, and our synthesis of the literature. Initially, we used existing theories of industrial organization and market design theory to evaluate the air travel industry and try to explain these paradoxical observations. A cross-case analysis of industry sectors within air travel led to a series of propositions. These propositions then were refined based on further literature review of related theory and a case study of financial securities.

Table 2 summarizes the questions, theoretical propositions, and support from the cases that have resulted from this iterative process. To a certain extent, we found empirical support for the predictions of Malone et al. [1987] of IT-driven moves to unbiased markets. On the other hand, our framework is constructive in explaining why other forms of market organization may prevail, such as biased

and opaque markets. We next discuss further how our theoretical development and synthesis overlap with existing theories, including the predictions of Malone et al. [1987], and where our unique contribution lies.

Table 2. Theory Development and Empirical Support

QUESTIONS	THEORY DEVELOPMENT	SUPPORT FROM CASES
Why do sellers make market info available to buyers despite the risk of losing info advantages? How can sellers compete by offering market info?	<i>IT</i> leads firms to compete in the dimension of <i>market transparency</i> (Link B, Prop.1).	Innovative mechanism designs in the Internet channel. Some examples are Capitalink and E*Trade in financial markets, and Expedia, Priceline.com, and Rosenbluth Travel in air travel.
What industry-specific factors influence the extent to which sellers use market information to compete? What role does IT play?	<i>Electronic product representation</i> facilitates competition with market information (Link D).	Bond markets are less transparent than equities. Corporate travel markets are less transparent than leisure markets.
	ITs that enable electronic product representation facilitate competition with market information (Link C, Prop. 2).	CRS and Internet technologies enabled transparent market mechanisms in air travel and financial markets.
What environmental forces influence the extent to which sellers use market information to compete? What role does IT play?	<i>Competitive</i> and <i>institutional forces</i> facilitate competition with market information (Link E).	Equity and leisure travel are more transparent than other sectors within their respective industries.
	<i>Price competition</i> and <i>anti-trust laws</i> lead sellers to tacitly collude through transparent electronic markets (Prop. 3).	Tacit collusion in equity and air travel markets. Five major U.S. airlines launched Orbitz.
Why does the availability of market information differ across industries? Why have unbiased electronic markets prevailed in some industries but not in others? Under which circumstances will transparent electronic markets prevail?	IT and forces that facilitate competition and electronic trade influence the extent of a move to transparent markets.	Bond markets and corporate travel markets are less transparent than sectors within their respective industries.
	In industries where IT and these forces are present, transparent electronic markets will prevail (Prop. 4).	There are fast-growing transparent electronic mechanisms in the equity markets and leisure air travel markets. Transparent B2B e-mkts dominate in travel agency ticket distribution.

The resulting propositions suggest that the move to transparent electronic markets is grounded on the use of IT in competitive strategy. All of our propositions argue that sellers will not only design market mechanisms to reduce transaction costs, but also to strategize and compete against their rivals. We

contend that it is this competitive pressure that, under certain conditions, leads most firms to favor and implement transparent electronic markets.

Nevertheless, the propositions carry forward some elements of transaction cost-based perspectives of industrial organization. For example, the reduction in information processing costs due to declining product complexity favors a move from biased and opaque markets to transparent markets, analogous to the existing rationale for the move from hierarchies to markets.

Malone et al. [1987, p. 492] predicted that “[p]roducers who start out by providing an electronic hierarchy or a biased electronic market will eventually be driven by competitive or legal forces to remove or significantly reduce the bias.” To their credit, this is precisely what we observe in leisure air travel and equities markets in the dimension of bias. However, we have seen that these transformations are not only driven by pro-competitive conditions and regulations. On a relative basis, the ability to represent a product electronically, either due to its information-intensive nature or due to emerging digital technologies that facilitate electronic representation, will moderate the pace or extent to which markets will become unbiased. Moreover, market transformations are not limited to the level of bias. The completeness and accuracy of information can also be affected by technological advances. Together, these factors may determine whether transparent markets prevail.

Through our analysis, we have shown how these forces interact with IT to facilitate or inhibit the move to transparent electronic markets. In particular, based on the cross-case analysis, we found that the degree of price competition and anti-trust laws moderate the extent to which IT favors transparent electronic markets outcomes.

Implications for Practitioners

Identifying the Relevant IT Artifacts. What are the IT artifacts in this research? This is an important question for practitioners, whose firms’ technological capabilities, market situation and strategic advantage are likely to be affected by the choices they make with respect to them. What IT artifacts facilitate the implementation of transparent market mechanisms? In the contexts

of our mini-cases, they are Web-based technologies in both financial services and air travel (e.g., Orbitz's Web-based transaction systems and search engines, and the supporting data base technologies), and global distribution systems (GDSs) and computerized reservation systems (CRSs) in air travel. Also, other market exchange-related technological innovations speed information about market supply and demand to the marketplace, making it ever more competitive. Some of these technologies today form the infrastructure for what Bergen et al. [2005] recognize as the new technological engine for implementing pricing and marketing strategy, and enhancing firm-level transaction-making capacity.

Technology Breakthroughs and Transparency Outcomes. Despite their potential impact on transparency, technological breakthroughs have not necessarily led to increases in transparency [Garbade and Silber, 1976; Picot et al., 1995; Tapscott and Ticoll, 2003]. Consider the U.S. financial markets after the invention of the telegraph in the mid-1800s. Although financial markets during that period in history were characterized by opaqueness and rampant fraud, the telegraph was the first technology to begin to create the basis for sharing market-relevant information over long distances, affecting efficiency and arbitrage opportunities between New York and London for foreign currency, and between New Orleans and New York for stock prices [Garbade and Silber, 1978]. But it was only after the financial crash in 1929 in the United States that markets became more transparent. This was due in large measure to intervention of the government through the Securities Act of 1933. Major players in the industry were able to continue reaping the benefits of opaque financial markets for decades, despite the ideal that the telegraph would bring information equitably to all market players nationally—including small investors. This continued well into the 1980s and 1990s, even with the “Black Monday” market crash of 1987 [Lucas and Schwartz, 1989]. We contend that in the Internet revolution most industries will experience a similar outcome. Sellers will continue to obtain benefits from market biases and opaqueness until they face competitive pressures and institutional forces that lead them to favor transparent electronic markets.

Some sectors of the air travel and financial securities markets have experienced a faster move to higher levels of market transparency since the late 1990s. The Internet, as the conduit for improved information flows between sellers and buyers, has been a key contributor. However, other factors were also instrumental, such as the relative ease of product representation of leisure air travel and equities, and competitive and regulatory developments in these industries that pre-dated the Internet revolution. As these conditions appear in other industries, we expect to see a similar evolution towards more transparent markets.

In a market environment where a move to transparent markets is expected to occur, first movers will have a preemptive competitive advantage. Therefore, we propose that practitioners should follow the development of technologies that facilitate product representation and competitive forces to assess whether a specific industry is likely to experience a move towards higher levels of market transparency.

IT Strategy Implications for Implementing Transparency. Our analysis to this point has assumed that external forces dictate the organization of markets. Putting that assumption aside we contend that, regardless of the impact of IT on the internal forces of the firm, external forces will continue to dictate the long-term outcomes. As the cost of IT investments decrease and the processing capabilities of computers increase, IT will allow firms to process data and generate more timely, more accurate, and more complete information. This will only accelerate the outcomes for market information predicted by our propositions.

Unbiased markets require the development of integrated or compatible databases and interoperable systems that make product and price information from all sellers available to buyers [Malone et al., 1987]. For complex products, the development of standards for product description, transaction formats, and data definitions is likely to facilitate higher structural levels of market transparency, and interfirm collaboration may be necessary [Wigand et al., 2005]. Technologies that facilitate conversion of product characteristics into digital

formats will enable market transparency in industries of complex and non-digital products.

As firms consider the implementation of transparent electronic market mechanisms, IT managers can play a key role to enable these market mechanisms. Industries such as air travel and financial securities have benefited from existing legacy systems such as electronic exchanges and CRSs, which integrate information from most suppliers and make individual sellers' systems interoperable. However, these systems typically have integrated architectures that make them very large and expensive. The Internet provides a powerful platform for IT strategists who are willing to break away from legacy system infrastructures to develop distributed, less expensive architectures that provide timely and accurate information without risking data integrity. Orbitz, for example, uses a distributed architecture with networked, low-cost Intel servers to run web-based software that searches and prices travel itineraries.

V. CONCLUSIONS

We have proposed a new unified theoretical framework for transparent electronic markets to explain and predict the role of IT on market structure transformations. The approach that we have taken in this work is not the usual example of theoretical development that we most often see in the literature. That often involves the use of multiple case studies as a means to identify the building blocks for new theory. In this research, we have developed a *theoretical framework* that is based not only on case studies but also on the unification of numerous theoretical arguments and perspectives from the prior literature. Our theoretical framework is innovative and potentially valuable for IT practitioners and researchers because it explains market structure in terms of the informational characteristics of a market. The core rationale of the framework is compelling. Sellers have economic incentives to adopt biased and opaque market mechanisms. While IT enables transparent market mechanisms, IT alone will not eliminate these incentives. Our analysis of the financial securities and air travel markets suggests that a combination of IT, competitive forces, institutional

forces, and enhanced electronic product representation triggered the move to transparent electronic markets.

We have taken advantage of the advanced stage of air travel and financial markets to develop a theoretical framework about the impact of IT on market structure. We applied an inductive approach appropriate in case study methodology [Eisenhardt, 1989] to examine the forces that play a role in the evolution of markets, towards high structural levels of market transparency. By analyzing multiple industry sectors within these settings (i.e., B2B and B2C bond and equities markets, B2B travel agency and corporate travel markets, and B2C leisure travel markets), we found that new IT-enabled informational strategies are being used to compete for buyers, which is creating structural changes in the level of bias, accuracy, and completeness of market information. In addition, we found that there are common forces that drive these changes in market structure.

Although the number of contexts that we have examined is not large, they nevertheless allowed the formulation of a set of propositions, in concert with the prior theoretical literature, which can be potentially applied to and tested in other industry settings. Additional in-depth case studies can be performed to validate and enhance these propositions. For example, an interesting case is that of the book market, where Amazon.com has led the path to greater levels of market transparency. Amazon.com has included secondary markets in customers' search requests to reduce biases and enable price discovery, despite the risk to their profits. In addition, in 2003 it introduced a "Search Inside the Book" feature on its Web site that allows consumers to browse pages of more than 120,000 books, to effectively increase product transparency in the industry [Economist, 2004].

With a larger dataset of industry cases, empirical analysis can be done to determine the impact of IT and other forces on market transparency. For example, cross-country studies by industry can be done to examine the impact of different degrees of competitiveness and legal forces on market structure. Similarly, cross-industry studies can be done to determine the impact of product characteristics on market transparency.

Finally, we propose additional theory-building efforts to examine the impact of IT on other dimensions of market design. For example, although auction markets for used products have proliferated thanks to the Internet, they are not necessarily transparent. A buyer that engages in one auction commonly accepts the biased nature of this market mechanism, where other product offers are not considered. The success of Internet-based auction markets for used products (e.g., www.ebay.com) suggests that the impact of IT on market structure should also be examined along other dimensions of market design, such as price discovery.

REFERENCES

- Airline Business and SITA. (August 2003) "IT Trends Survey," *Airline Business Magazine*, pp. 40-47.
- Allen, H., J. Hawkins, and S. Sato. (2001) "Electronic Trading and its Implications for Financial Systems," in *Electronic Finance: A New Perspective*, Bank for International Settlements, Basle, Switzerland.
- Anandalingam, G., Day, R. W., and Raghavan, S. (2005) "The Landscape of Electronic Market Design," *Management Science*, 51(3), pp. 316-327.
- Bakos, J.Y, and E. Brynjolfsson. (1993) "IT, Incentives, and the Optimal Number of Suppliers," *Journal of Management Information Systems*, 10(2), pp. 37-53.
- Bergen, M., R. J. Kauffman and D. W. Lee. (2005) "Discovering Price Rigidity and Price Adjustment Patterns on the Internet: Evidence from the E-Bookselling Industry," *Journal of Management Information Systems*, 22(2), 57-90.
- Benbasat, I., Goldstein, D. K., and Mead, M. (1987) "The Case Research Strategy in Studies of Information Systems," *MIS Quarterly*, 11(3), pp. 369-386.
- Bond Market Association. (1997a, 1998-2003) *eCommerce in the Fixed-Income Markets: Review of Electronic Transaction Systems*, New York, NY.
- Bond Market Association. (1997b) *Special Survey on the Future of Electronic Bond Trading Systems*, New York, NY.
- Campbell, C., Gautam, R., and Muhanna, W. A. (2005) "Search and Collusion in Electronic Markets," *Management Science*, 51(3), pp. 497-507.
- Chircu, A.M. and R. J. Kauffman. (2001) "Maximizing the Value of Internet-Based Corporate Travel Reservation Systems," *Communications of the ACM*, 44(11), pp. 57-63.
- Christie, W. G. and Schultz, P. H. (1995) "Did NASDAQ Market Makers Implicitly Collude?" *Journal of Economic Perspectives*, 9(3), pp. 199-208.

- Clemons, E. K., S. P. Reddi, and M. C. Row. (1993) "The Impact of IT on the Organization of Economic Activity: The 'Move to the Middle' Hypothesis," *Journal of Management Information Systems*, 10(2), pp. 9-35.
- Clemons, E.K. and M. C. Row. (1991) "IT at Rosenbluth Travel: Competitive Advantage in a Rapidly Growing Global Service Company," *Journal of Management Information Systems*, 8(2), pp. 53-79.
- Clemons, E. K., and W. B. Weber. (1990) "The Big Bang at the London Stock Exchange," *Journal of Management Information Systems*, 6(4), pp. 41-60.
- Coase, R. H. (1937) "The Nature of the Firm," *Economica*, 4, pp. 386-405.
- Copeland, D. G., and J. L. McKenney. (1988) "Airline Reservation Systems: Lessons from History," *MIS Quarterly*, 12(3), pp. 353-370.
- Cusumano, M.A. and A. Takeishi. (1991) "Supplier Relations and Management: A Survey of Japanese, Japanese-Transplant, and U.S. Auto Plants," *Strategic Management Journal*, 12(8), pp. 563-588.
- Economides, N. (2001) "The Impact of the Internet on Financial Markets," *Journal of Financial Transformation*, 1(1), pp. 8-13.
- Economist*. (May 15, 2004) "A Survey of E-Commerce," Special Section, pp. 5-7.
- Eisenhardt, K. M. (1989) "Building Theories from Case Study Research," *Academy of Management Review*, 14(4), pp. 532-550.
- Garbade, K. and W. Silber. (1976) "Price Dispersion in the Government Securities Market." *Journal of Political Economy*, 84(4), pp. 721-740.
- Garbade, K. and W. Silber. (1978) "Technology, Communication and the Performance of Financial Markets: 1840-1975." *Journal of Finance*, 33(3), pp. 819-832.
- Granados, N., A. Gupta, and R. J. Kauffman. (2005) "Transparency Strategy in Internet-Based Selling." In K. Tomak (ed.), *Advances in the Economics of IS*, Harrisburg, PA: Idea Group Publishing, pp. 80-112.
- Hasbrouck, J.(1995) "Trade and Quote Transparency: Principles and Prospects for the Year 2000." In R. A. Schwartz (Ed.), *Global Equity Markets: Technological, Competitive, and Regulatory Challenges*, Irwin Professional Publishing, New York, NY, pp. 218-226.
- Hess, C.M. and C. F. Kemerer. (1994) "Computerized Loan Origination Systems: An Industry Case Study of the Electronic Markets Hypothesis," *MIS Quarterly*, 18(3), pp. 251-275.
- Kauffman, R. J., and Y. Lu. (2005) "Electronic Trading Systems and Their Impacts on the Structure of Bond Markets," Working paper, MIS Research Center, Carlson School of Management, University of Minnesota, Minneapolis, MN, in process.
- Kauffman, R. J., and H. Mohtadi. (2004) "Proprietary and Open Systems Adoption in E-Procurement: A Risk-Augmented Transactions Cost Perspective,"

Journal of Management Information Systems, 21(1), pp. 137-166.

Kauffman, R. J., and H. Mohtadi. (2005) "Analyzing Interorganizational Information Sharing Strategies in B2B E-Commerce Supply Chains," Working paper, MIS Research Center, Carlson School of Management, University of Minnesota, Minneapolis, MN.

Klein, S. and C. Loebbecke. (2003) "Emerging Pricing Strategies on the Web: Lessons from the Airline Industry," *Electronic Markets*, 13(1), pp. 46-58.

Levecq, H., and B. W. Weber. (2002) "Electronic Trading Systems: Strategic Implications of Market Design Choices," *Journal of Organizational Computing and E-Commerce*, 12(1), pp. 85-103.

Levine, M. E. (1987) "Airline Competition in Deregulated Markets: Theory, Firm Strategy, and Public Policy," *Yale Journal of Regulation*, 4(2), pp. 393-494.

Lucas, H. C., Jr., and R. A. Schwartz. (1989) *The Challenge of Information Technology for the Securities Markets: Liquidity, Volatility, and Global Trading*. Dow Jones-Irwin, Homewood, IL.

Madhavan, A. (2000) "Market Microstructure: A Survey," *Journal of Financial Markets*, 3(3), pp. 205-258.

Malone, T. W., J. Yates, and R. I. Benjamin. (1987). "Electronic Markets and Electronic Hierarchies," *Communications of the ACM*, 30(6), pp. 484-497.

Pagano, M., and A. Roell. (1996) "Transparency and Liquidity: A Comparison of Auction and Dealer Markets with Informed Trading," *Journal of Finance*, 51(2), pp. 579-611.

PhocusWright. (2003) "Online Corporate Travel Update 2003-2006: Market Share, Strategy, Forecasts, Commentary," Sherman, CT.

Picot, A., C. Bortenlaenger and H. Roehrl. 1995. "The Automation of Capital Markets." *Journal of Computer-Mediated Communication*, 1(3), online at jcmc.indiana.edu/vol1/issue3/picot.html (current December 27, 2005).

Porter, M. E. (2001) "Strategy and the Internet," *Harvard Business Review*, 79(1), pp. 62-78.

Reinan, J. (May 5, 2004) "Web Firms Pursue Corporate Travelers," *Minneapolis Star Tribune*, Section D, pp. 1-2.

Riley, J., and R. Zechhauser. (1983) "Optimal Selling Strategies: When to Haggle, When to Hold Firm," *Quarterly Journal of Economics*, 98(2), pp. 267-290.

Reuters. (June 7, 2004) "EU Airlines No Longer Discriminate on Prices," Press release, New York, NY.

Salkever, A. (November 15, 1999) "A Dogfight in Cyberspace: The Online Travel Biz Heats Up," Daily Briefing, *Business Week Online*, www.businessweek.com/pl/bwdaily/dnflash/nov1999/nf91115a.htm (current December 26, 2005).

Schwartz, R. A. (1995) *Global Equity Markets: Technological, Competitive, and Regulatory Challenges*, New York, NY: Irwin Professional Publishers.

- Spulber, D. F. (1999) "*Market Microstructure: Intermediaries and the Theory of the Firm*," New York, NY: Cambridge University Press.
- Stigler, G. J. (1961) "The Economics of Information," *Journal of Political Economy*, 69(3), pp. 213-225.
- Tapscott, D. and D. Ticoll (2003) "*The Naked Corporation: How the Age of Transparency will Revolutionize Business*," New York, NY: Free Press.
- United States Census Bureau. (August 20, 2004) "U. S. Department of Commerce News," Washington, DC. www.census.gov/mrts/www/data/pdf/04Q2.pdf (current December 26, 2005).
- Varian, H. R. (1999) "Market Structure in the Network Age." Working paper, School of Information, University of California, Berkeley, CA, available at www.sims.berkeley.edu/~hal/Papers/doc/doc.html (current December 27, 2005).
- Wang, E. T. G. and A. Seidmann (1995) "Electronic Data Interchange: Competitive Externalities and Strategic Implementation Policies." *Management Science*, 41(3), pp. 401-418.
- Wigand, R. T., C. W. Steinfeld, and L. Markus (2005) "Information Technology Standards Choices and Industry Structure Outcomes," *Journal of Management Information Systems*, 22(2), pp. 165-191.
- Zaheer, A. and Venkatraman, N. (1994) "Determinants of Electronic Integration in the Insurance Industry: An Empirical Test," *Management Science*, 40(5), pp. 549-566.
- Zhu, K. (2004). "Information Transparency of Business-to-Business Electronic Markets: A Game-Theoretic Analysis," *Management Science*, 50(5), pp. 670-685.

ACKNOWLEDGMENTS

Earlier versions of this paper were presented at the JAIS Theory Workshop, Washington, DC, December 2004, the 2005 Hawaii International Conference on Systems Science, Kona, HI, January 2005, and the JAIS Theory Building Master Class, Omaha, Nebraska, August 2005. The authors thank the anonymous reviewers, as well as Cynthia Beath, Eric Clemons, Sirkka Jarvenpaa, Yaobin Lu, Hank Lucas, Kalle Lyytinen, Ron Weber, Lynne Markus, Joan Rodon, Rajiv Sabherwal and Bruce Weber for helpful comments on this and related work that shaped the perspectives we offer. Nelson Granados thanks the Carlson School of Management, and the Graduate School of the University of Minnesota for doctoral fellowship support. Alok Gupta's work is supported by the National Science Foundation under Grant #IIS-0092780, for which he kindly acknowledges funding. Rob Kauffman thanks the participants in the IDSc 8801 Doctoral Seminar in Economics and IS, where technology and market transformation are often discussed, and the MIS Research Center for partial support.

ABOUT THE AUTHORS

Nelson Granados is a Ph.D. candidate in the Information and Decision Sciences Department at the Carlson School of Management, University of Minnesota. His research interests are related to the strategic and economic consequences of IT-enabled transparency in Internet-based selling. His current work focuses on the impact of information transparency on consumer demand, market prices and the broader impact on market structure, with a special focus on the air travel industry. His other research is forthcoming in *Information Systems and eBusiness Management*, and was published in a chapter of the book *Advances in the Economics of Information Systems*, edited by K. Tomak (Idea Group Publishing, Harrisburg, PA, 2005). He has presented his research at the *INFORMS Conference on Information Systems and Technology (CIST)*, the *JAIS Theory Workshop*, the *Hawaii International Conference on System Sciences (HICSS)*, the *Workshop on IT and Systems (WITS)*, the *Workshop on IS and Economics (WISE)*, and the *American Conference on Information Systems (AMCIS)*. Prior to joining the Ph.D. program, he worked for Northwest Airlines in Japan, the United States, and Europe in multiple marketing management positions. He was also a product manager for enterprise systems at IBM Colombia.

Alok Gupta is a Professor in the Information and Decision Sciences Department at the Carlson School of Management, University of Minnesota. He received his Ph.D. in MSIS from UT Austin in 1996. His research has been published in various IS, economics, and computer science journals such as *Management Science*, *MIS Quarterly*, *Information Systems Research*, *Communications of the ACM*, *Journal of Management Information Systems*, *Decision Sciences*, *Journal of Economic Dynamics and Control*, *Computational Economics*, *Decision Support Systems*, *IJFMS*, *IEEE Internet Computing*, *Journal of Organizational Computing*, and *Information Technology and Management*. He received a prestigious NSF career award in 2001 for his research on online auctions, and has continued that research. He serves on the

editorial boards of *ISR*, *DSS* and the *Brazilian Electronic Journal of Economics*. He also serves on the *MISQ* policy committee.

Robert J. Kauffman is Director of the MIS Research Center, and Professor and Chair in the Information and Decision Sciences Department at the Carlson School of Management, University of Minnesota. He previously worked in international banking, and served on the faculty of New York University (1988-2004) and the University of Rochester (1992). His graduate degrees are from Cornell University (M.A., 1979) and Carnegie Mellon University (Ph.D., 1988). His research focuses on senior management issues in IS strategy and business value, IT infrastructure investments, technology adoption, e-commerce and e-markets, and supply chain management. His research has been published in *Organization Science*, *Journal of Management Information Systems*, *Communications of the ACM*, *Management Science*, *MIS Quarterly*, *Information Systems Research*, *Decision Sciences*, and other leading IS, economics and computer science journals and conferences. He recently won best research paper awards at INFORMS CIST in 2003 and 2004, HICSS in 2004, and ICEC in 2005.